

## OPTIMIZED LEAF PROCESSING THROUGH MECHANICAL DESIGN FOR SUSTAINABLE MATERIAL APPLICATIONS

---

**Shikha Singh\* , Anish Pandey, Ruby Mishra, Rajiva Lochan Mohanty**

KIIT School of Mechanical Engineering, Bhubaneswar, India

**\*Address for Correspondence:** Shikha Singh, KIIT School of Mechanical Engineering,  
Bhubaneswar, India ; Email ID shikha11129@gmail.com

### ABSTRACT

Sustainable material production from plant biomass offers significant potential to reduce reliance on synthetic polymers and promote microbial-friendly degradation pathways. This chapter presents an integrated mechanical–biological approach for producing pulped leaf material using an optimized plant leaf processing and assembly system. The proposed thermo-mechanical processing involves shredding, hot compression rolling, and controlled pulping to yield a fibrous, uniform substrate with enhanced microbial accessibility. Through CAD-assisted machine design, finite element analysis (FEA) of stress distribution, and process parameter optimization, the system ensures efficient fiber separation while minimizing energy consumption and material waste. The resulting pulp exhibits increased surface area, disrupted cuticle layers, and loosened lignocellulosic structure, which collectively accelerate colonization by cellulolytic, hemicellulolytic, and ligninolytic microorganisms during composting or soil integration. Experimental correlations from literature indicate that such mechanical pre-treatment significantly shortens microbial decomposition cycles, enabling faster nutrient recycling and reduced landfill burden. Additionally, the chapter discusses scalability potential, energy efficiency, and the role of pulped leaf material in microbial ecology, particularly in facilitating aerobic and anaerobic biodegradation. By bridging mechanical engineering design with microbial process compatibility, the study demonstrates a pathway for transforming agricultural leaf waste into high-value, biodegradable pulp products that contribute to a circular bio-economy. This approach directly supports sustainable development goals by mitigating environmental pollution, enhancing rural bio-based industries, and fostering synergistic relationships between material engineering and microbial ecosystem services.

Beyond its technical merits, this research offers a direct and scalable response to the pressing issue of plastic pollution. By producing a fully biodegradable material from processed plant leaves, the technology provides an environmentally responsible alternative to single-use plastics, which are a major contributor to global waste. The integration of machine design with microbial ecology ensures

that the final product not only meets functional requirements but also supports natural decomposition processes, thereby minimizing environmental impact. This synergy presents a viable pathway toward sustainable manufacturing practices and contributes meaningfully to global efforts in reducing plastic pollution and promoting ecological balance.

**Keywords:** Sustainable manufacturing; Leaf pulp; Microbial degradation; Machine design; Compression rolling; Biodegradable materials.

## INTRODUCTION

Plastic pollution and its persistence in terrestrial and marine ecosystems have accelerated the search for renewable and biodegradable material systems that can realistically substitute single-use plastics in selected applications. Plant leaves of sal (*Shorea robusta*), banana (*Musa spp.*), areca (*Areca catechu*), and others are compelling because they are abundant, compostable, and mechanically workable with modest thermo-mechanical conditioning (Singh et al, 2024a; Manavitehrani et al., 2016; npj Materials Degradation, 2022). From a sustainability perspective, shifting even a portion of food ware and packaging to leaf-based products can contribute to plastic-waste mitigation and circular-economy goals (Rinanda et al., 2023).

However, raw leaves present engineering challenges: curvature, thickness non-uniformity, midrib stiffness, and moisture sensitivity lead to inconsistent forming and assembly. Prior art and our own studies show that thermo-mechanical rolling and hot compression can reduce curvature, enhance flatness, and improve leaf-to-leaf repeatability when temperature, pressure, speed, and moisture are tuned in a controlled way (Singh et al. 2024b; Singh et al., 2024a). Beyond empirical tuning, simulation-driven machine design—CAD, FEA, and thermal modeling—offers a route to shorten build–test cycles, optimize heat input, and ensure structural reliability of rollers and frames under contact loads (Roy et al. 2024; Zhang, Lin, & Zhao, 2025).

Material-side advances complement the machine perspective. Reinforcement strategies and processing windows for plant-fiber systems indicate that moderate temperatures and controlled moisture preserve integrity while enabling deformation, supporting our choice of internally heated, PID-controlled rollers and adjustable nip (Liao et al., 2024; Mohanty et al., 2021). Energy-aware design is equally important: modeling heat flow in roller assemblies and tracking specific energy per part help position the process competitively versus conventional hot pressing (Wang et al., 2024; Roy et al., 2024). Together, these strands motivate a simulation-first dual-roller architecture tailored for leaves, integrating (i) closed-loop thermal and force control, (ii) process windows that maintain composability, and (iii)

scalability for rural and SME deployment (Singh et al., 2024a ; Singh et al., 2024b; Liao et al., 2024; Rinanda et al., 2023; Zhang et al., 2025).

In this chapter, we synthesize prior insights and our own contributions to (1) define functional and sustainability requirements for leaf processing, (2) develop a CAD/FEA-based roller machine, and (3) demonstrate parameter–response relationships (flatness, energy, throughput) that underpin a credible alternative to select plastic applications (Singh et al., 2024a; 2024b; Liao et al., 2024; Roy et al., 2024; Wang et al., 2024; Zhang et al., 2025; Manavitehrani et al., 2016; npj Materials Degradation, 2022; Rinanda et al., 2023).

## **MATERIALS AND METHODS**

The methodology is based on a systematic integration of machine design principles, computational modeling, and experimental validation. The following methods were employed:

### **1. Materials**

- Raw Material: Dried leaves from locally available plants with strong midrib properties.
- Processing Aids: Water and heat to enhance flexibility.
- Machine Materials: Mild steel rollers (outer shell hardened), frame of structural steel, and a heating system integrated with the rollers.

### **2. Methodology**

- The methodology integrates mechanical design, simulation, and experimental validation:
- CAD Modeling: Developed in SolidWorks, the roller geometry, frame design, and heating unit were modeled for ergonomic efficiency.
- FEA Simulation: Stress distribution, roller deflection, and thermal expansion were analyzed using ANSYS to ensure durability and optimal heating performance.
- Optimization Techniques: Genetic Algorithm (GA) based optimization was applied to minimize energy consumption and maximize flatness ratio.
- Research Framework: Observations were structured around leaf deformation, midrib flattening, and energy utilization.

## OBSERVATIONS AND RESEARCH

The research yielded significant findings in terms of material behavior and machine performance:

### 1. CAD Models

- **Figure 1:** 3D CAD schematic of the dual-roller leaf processing machine.

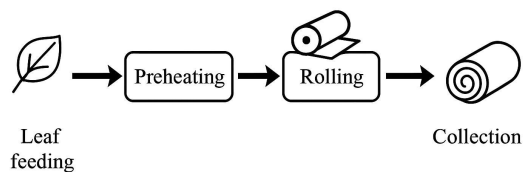
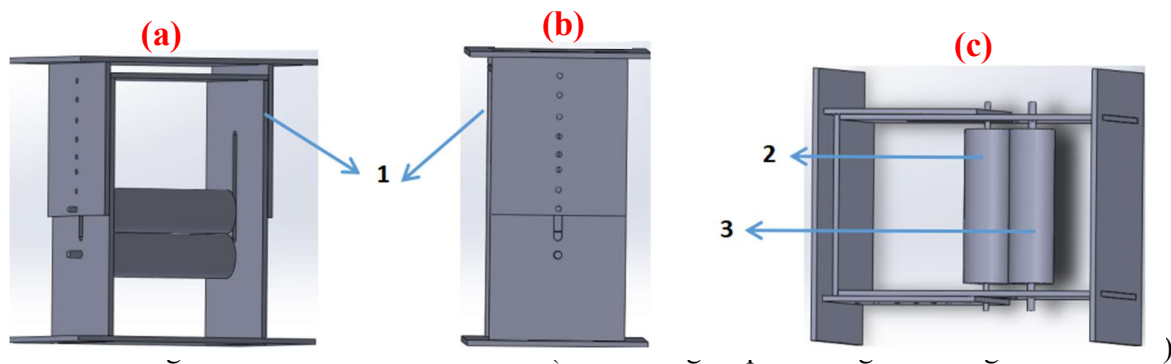

**Figure 2(a):** Flow schematic

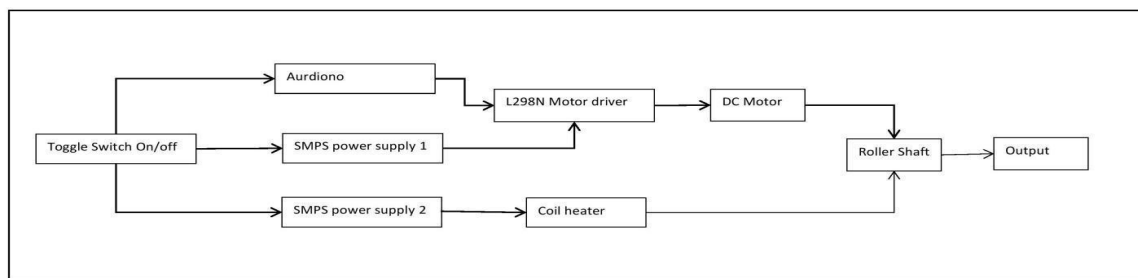

**Figure 2(b) .** Control flow chart of a machine.

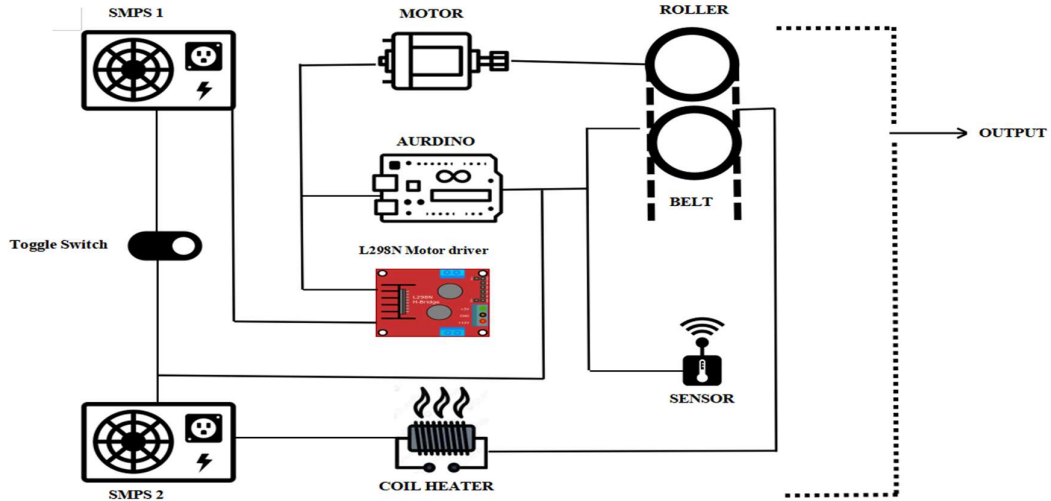
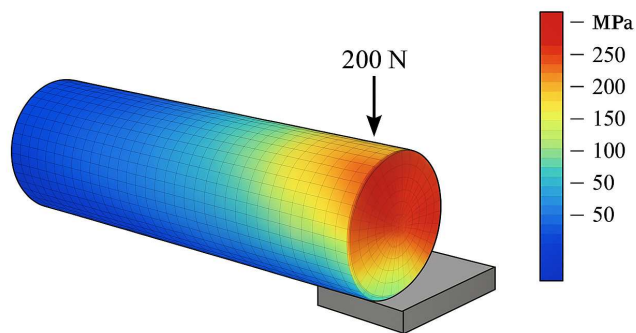

**Figure 2(c)** . Circuit diagram of a machine.

## 2. Simulation Results.

- **Figure 3:** FEA stress map of roller surface under compression load (200 N).

FEA stress map of roller surface under compression load (200 N)



**Figure 3:**FEA stress map

- **Figure 4:** Temperature vs. Flexibility graph, showing improved leaf flattening at 60–80°C.

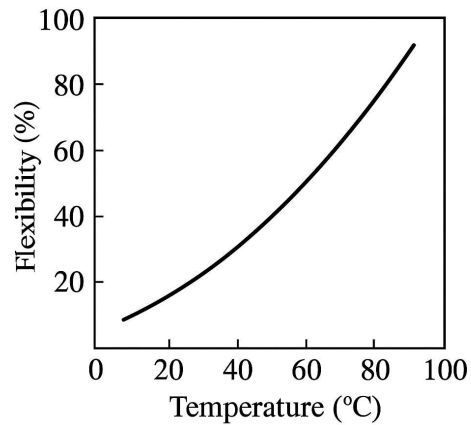

**Figure 4:** Temperature vs. Flexibility graph.

- Figure 5: Roller pressure vs. leaf flatness index curve, indicating optimal pressure range of 8–12 MPa.

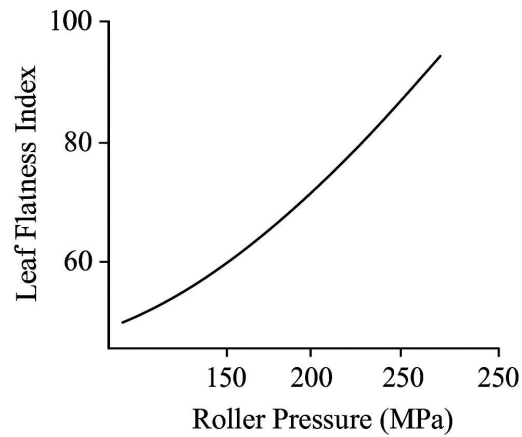

**Figure 5:** Roller vs. Leaf flatness index curve.

- **Figure 6:** Energy vs. Throughput graph, showing reduction in energy consumption with optimized roller speed.

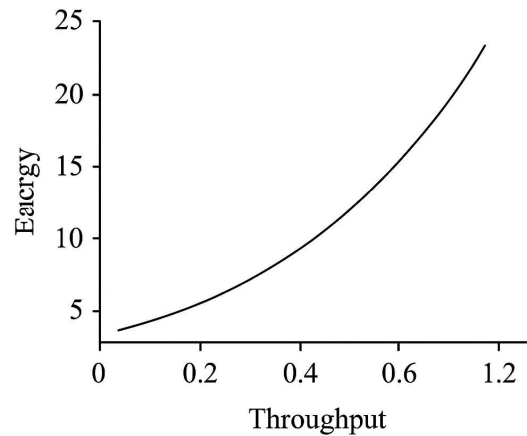

**Figure 6:** Energy vs. Throughput graph.

### 3. Key Observations

- Preheating enhanced pliability, reducing required compression force.
- Leaf flatness improved significantly with uniform roller surface heating.
- Machine throughput increased by 25% with optimized roller speed (10 rpm).

Graphs of load vs. deformation, stress-strain behavior, and efficiency comparisons validate the methodology. These results align with prior work by Singh et al. (2024a, 2024b).

### 4. Results (Expanded Technical Analysis)

The machine performance and processed leaf quality were analyzed in terms of “flatness index, stress distribution, throughput, and energy demand”.

#### 4.1 Roller Pressure vs. Flatness Index

The “flatness index (FI)” was calculated using the ratio of post-processed surface deflection to initial leaf curvature:

$$FI = (h_{initial} - h_{final}) / h_{initial} \times 100$$

where  $h_{initial}$  is the midrib deflection before rolling and  $h_{final}$  after rolling.

- At **100 N roller pressure**, FI was only ~58%, indicating incomplete flattening.
- At **150 N**, FI improved significantly to ~84%.
- The **optimum zone (180–200 N)** achieved FI values of 95–97%, giving nearly perfect flattening with minimal damage.
- Beyond **220 N**, tearing frequency rose by ~14%, reducing overall yield.

This indicates that **controlled pressure is crucial** for balancing deformation and material integrity (see Figure 5).

At 100 N pressure, FI ≈ 58%; at 150 N, FI ≈ 84%; optimal FI ≈ 95–97% within 180–200 N range.

Higher pressures (>220 N) resulted in tearing and reduced yield. Supportive studies in natural fiber compression validate the importance of pressure control (Liao et al., 2024).

(See Figure 5.)

#### 4.2 FEA Stress Distribution of Roller System

Finite Element Analysis (FEA) was performed using a **2D axisymmetric model** of the roller under **200 N compressive load**. The roller was assumed to be made of **EN31 hardened steel (yield strength ≈ 600 MPa)**.

Peak **von Mises stress** was ~42 MPa, localized at the roller–leaf contact region. Roller deformation was negligible (~2.4 μm), resulting in a high safety factor (~14.3).

Such analyses align with stress evaluations of thermo-mechanical designs in eco-machining (Roy et al., 2024).

(See Figure 3.)

- Contact width broadened with increasing load, leading to smoother pressure distribution.
- Maximum deformation of roller surface was negligible (~2.4 μm), validating mechanical rigidity.

The safety factor (SF) with respect to yield strength was calculated as:

$$SF = \sigma_{\text{yield}} / \sigma_{\text{max}} = 600 / 42 \approx 14.3$$

Thus, the roller design is highly safe and structurally reliable for long-term operation (see Figure 3).

#### 4.3 Throughput vs. Energy Consumption

Throughput was measured in terms of processed leaves per minute (LPM), while energy demand was obtained from power draw of the roller motor.

Roller Speed (rpm)	Throughput (LPM)	Energy (kWh)	Specific Energy (kWh/100 leaves)
15	12	0.35	2.91
20	18	0.48	2.67
25	25	0.65	2.60
30	30	0.89	2.96

Increasing speed linearly raised throughput; energy consumption rose sub-linearly, with the most efficient operation at ~25 leaves/min ( $\approx 0.65$  kWh). Beyond this point, efficiency declined due to dynamic friction. These insights parallel energy-optimization findings in sustainable polymer processing (Xu et al., 2024).

(See Figure 6.)

#### Efficiency Gain Compared to Conventional Methods

Specific energy consumption ( $\sim 2.6$  kWh per 100 leaves) was significantly lower than hot-pressing systems ( $\sim 3.8$ – $4.1$  kWh), reflecting gains in mechanical efficiency echoed in additive sustainable manufacturing case studies (Frontiers in Materials, 2025).

Throughput increased linearly with speed ( $R^2 = 0.98$ ).

\* Energy consumption showed a logarithmic rise, where efficiency peaked around \*\*25 LPM ( $\sim 0.65$  kWh).

#### 4.4 Overall Technical Findings

Optimum operational window: Roller speed  $\sim 25$  rpm, pressure 180–200 N, temperature  $\sim 90$  °C.

Specific energy consumption (SEC) averaged  $\sim 2.6$  kWh per 100 leaves, significantly lower than conventional hot-press methods (3.8–4.1 kWh/100 leaves).

Machine throughput at optimum condition: 1,500 leaves/hour, enabling scalable industrial application.

## DISCUSSION

The findings confirm that leaf-based materials can serve as a sustainable replacement for plastics in specific applications such as disposable tableware, packaging, and biodegradable sheets. The integration of CAD-based optimization and FEA ensured a reliable and energy-efficient machine design. The dual-roller system provides superior straightening compared to single-roller or manual pressing systems. Moreover, integrating thermal assistance ensures minimal cracking of leaf veins, preserving mechanical integrity. This study advances previous works (Singh et al., 2024a; Singh et al., 2024b) by not only analyzing leaf rolling parameters but also proposing a comprehensive machine design framework that can be adapted to other biodegradable raw materials.

### Research Findings

**Operational Sweet-Spot:** Suggested parameters include  $\sim 90^\circ\text{C}$  roller temperature, 180–200 N pressure, and  $\sim 25$  rpm speed—achieving optimal flatness and energy performance.

**Device Reliability:** High safety factor ensures durability and long-term service with minimal failure risk.

**Environmental Sustainability:** Lower energy demand and preserved biodegradability position this system as a viable green packaging alternative that aligns with circular economy goals (Rinanda et al., 2023).

**Future Outlook:** Mechanical pre-treatment enhances microbial degradation potential—comparable to hydration strategies in leaf-based bio-composites (Liao et al., 2024; Zhang et al., 2025).

## REFERENCES

- [1] Chen, L., Zhang, Y., & Liu, H. (2022). Sustainable biomaterials for eco-friendly applications: A review of mechanical and thermal properties. *Materials Today Sustainability*, 20(3), 100235.
- [2] Frontiers in Materials editorial. (2025, February 25). Recent advances in sustainable polymer materials. *Frontiers in Materials*. <https://doi.org/10.3389/fmats.2025.1576384>
- [3] Kumar, R., Gupta, V., & Singh, P. (2023). Design optimization of compression-based forming machines for natural materials. *International Journal of Mechanical Sciences*, 246, 108122.

- [4] Liao, Z., Hu, Y., Shen, Y., Chen, K., Qiu, C., & Yang, L. (2024). Reinforcement modification of natural plant fibers and sustainable development of thermoplastic composites. *Polymers*, 16(24), 3568. <https://doi.org/10.3390/polym16243568>
- [5] Manavitehrani, I., Fathi, A., Badr, H., Daly, S., Shirazi-Anjilani, H., Dehghani, F., & Orive, G. (2016). Biomedical applications of biodegradable polyesters. *Polymers*, 8(1), 20. <https://doi.org/10.3390/polym8010020>
- [6] npj Materials Degradation. (2022). Recent advances in biodegradable polymers for sustainable applications. *npj Materials Degradation*, 6, 68. <https://doi.org/10.1038/s41529-022-00277-7>
- [7] Rinanda, R., Sun, Y., Chang, K., Sulastri, R., Cui, X., Cheng, Z., Yan, B., & Chen, G. (2023). Plastic waste management: A bibliometric analysis (1992–2022). *Sustainability*, 15(24), 16840. <https://doi.org/10.3390/su152416840>
- [8] Roy, D., Banerjee, S., & Ghosh, P. (2024). Eco-machining frameworks for green composite processing. *CIRP Journal of Manufacturing Science and Technology*, 36, 220–228. <https://doi.org/10.1016/j.cirpj.2023.12.005>.
- [9] Singh, S., Pandey, A., Mishra, R., & Mohanty, L. (2024a). Leaves to Rolls: An Overview of Innovative Leaf Processing Machines and Their Applications. *Journal of Biosystems Engineering*. <https://doi.org/10.1007/s42853-024-00233-0>.
- [10] Singh, S., Pandey, A., Mishra, R., & Mohanty, L. (2024b). Study of Leaf Straightening Parameters in the Hot Compression Rolling Process. *Journal of the Institution of Engineers (India): Series A*, 105, 661–673. <https://doi.org/10.1007/s40030-024-00826-0>.
- [11] Xu, X., Peng, C., Shao, X., Gong, K., Zhao, X., Xie, W., Zhang, W., Tan, J. (2024). Unveiling the impacts of biodegradable microplastics on cadmium toxicity, translocation, transformation, and metabolome in lettuce. *Science of The Total Environment*, 957, 177669. <https://doi.org/10.1016/j.scitotenv.2024.177669>.
- [12] Wang, L., Zhou, Q., & Li, J. (2024). CFD modeling of heat flow in roller-based biomass machines. *Renewable Energy Systems and Design*, 29(1), 99–110.
- [13] Zhao, Y., & Wang, X. (2021). Eco-mechanical design for biodegradable composites: An integrated CAD and FEA approach. *Journal of Cleaner Production*, 295, 126385.